

2125
B.E. (Electrical and Electronics Engineering)
Third Semester
PC-EE-4302: Control Engineering - I

Time allowed: 3 Hours

Max. Marks: 50

NOTE: Attempt five questions in all, including Question No. 1 which is compulsory and selecting two questions from each Part. Graph paper and semi-log graph paper are allowed. Assume any missing data.

x-x-x

- (a) What are the necessary conditions of stability in control system?
(b) Draw torque-voltage analogy table.
(c) Write advantages of decade system over octave system.
(d) Write limitations of R-H criterion.
(e) Explain how potentiometer can act as error detector in control system?
(5*2)

PART-A

- (a) What are analogous systems? Derive F-V and F-I analogies. Also draw their equivalent circuits.
(b) What is the significance of feedback element in control system? Explain its effects on sensitivity and dynamic behaviour of system.
(5, 5)
- Determine transfer function using block diagram algebra and verify the result using Mason's Gain Formula.
(5, 5)

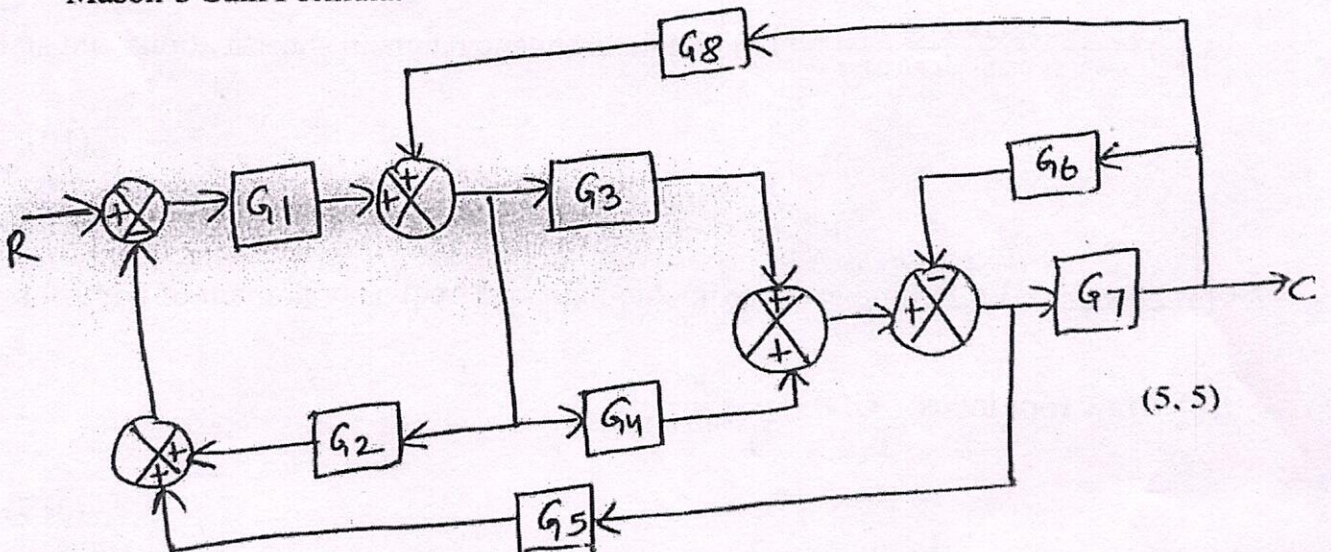

P.T.O.

(2)

4. (a) The feedback system shown below oscillates at frequency 2 rad/s. Find the values of 'K' and 'a'.

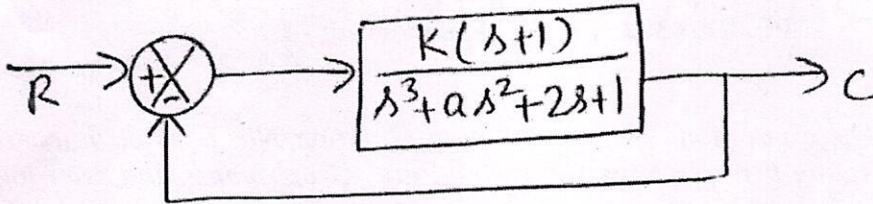

- (b) Unity feedback system has open loop transfer function as:

$$G(s) = \frac{K(1+2s)}{s^2(s+20)(s+30)}$$

Find static error coefficients and value of K to limit the steady state error to 10 if input is $r(t) = 1 + 10t + 20t^2$

(5, 5)

PART-B

5. Construct complete Nyquist plot for unity feedback control system whose open loop transfer function is $G(s)H(s) = \frac{K}{s(s^2+2s+2)}$. Find stability.

(10)

6. Sketch the Bode Plot for the following system:

$$G(s) = \frac{36(1+0.2s)}{s^2(1+0.05s)(1+0.01s)}$$
 Find all the frequency domain specifications and stability

(10)

7. (a) Discuss correlation between time domain and frequency domain of control system.

(b) Draw root locus: $G(s) = \frac{K}{s(s^2+4s+8)}$

(3, 7)