

2125  
B.E. (Mechanical Engineering)  
Third Semester  
MEC-304: Machine Drawing

Time allowed: 3 Hours

Max. Marks: 50

**NOTE:** Attempt five questions in all, including Question No. 1 (Part-A) which is compulsory and selecting two questions each from Part B-C. Assume suitably the missing data, if any. All dimensions are in mm, if not mentioned otherwise. Supplement your answer with neat and labeled sketches wherever required. All software related questions must be answered with respect to AutoCAD software. All questions carry 10 marks.

x-x-x

**Part-A**

- 1
- (i) Define limit tolerance and explain how it differs from plus-minus tolerance.
  - (ii) What are datums in geometric tolerancing? Give one example.
  - (iii) What are set screws and studs? State one typical use of each in mechanical assemblies.
  - (iv) What information is generally included in a tolerance block on a working drawing?
  - (v) What is the purpose of the 3D Orbit tool in AutoCAD 3D modeling?

**Part-B**

- 2 Interpret the meaning of the geometrical tolerances shown in next figures.

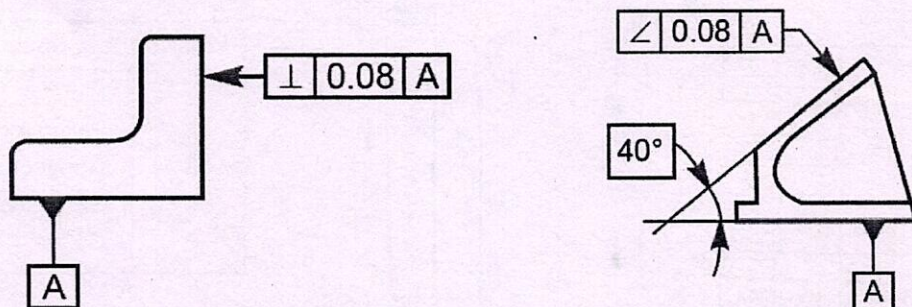

- 3 Compare square threads, Acme threads, and trapezoidal threads in terms of geometry, strength, efficiency, and applications. Explain the engineering applications where Acme threads are preferred over square threads, such as in lead screws of lathes or power transmission devices. Include relevant sketches and descriptions of thread profiles.
- 4 A machine sub-assembly consists of two plates joined by four bolts. The top plate dimensions are 250 × 150 × 10 mm, and bolt holes are located at a 20 mm offset from each corner. Prepare a freehand layout showing isometric view, marking dimensions and hole locations with tolerance values. Also, write a step-by-step procedure to be followed for creating a solid model of this assembly in AutoCAD.

(2)

Part-C

- 5 Assemble the parts of the Stuffing Box shown in next figure and draw its orthographic views in first angle projection.

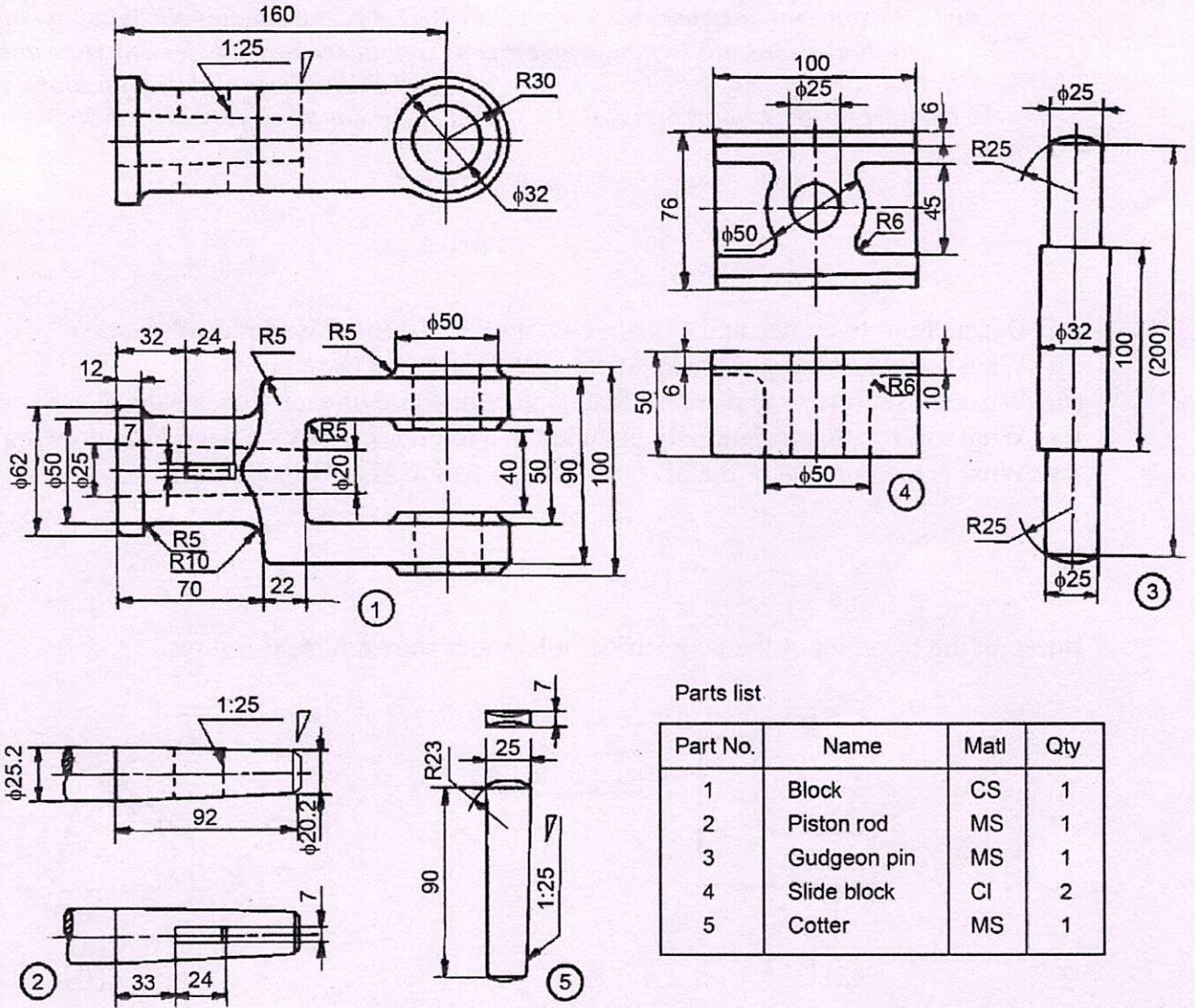

- 6 Write the step-by-step commands / procedures to be followed for creating 3D model of components shown in question number 5 in AutoCAD.
- 7 Write the step-by-step commands / procedures to be followed for creating a 3D model of a Knuckle Joint in AutoCAD.